



# Vort Prometeo HR400 Heat Recovery Ventilation



[www.atc.ie](http://www.atc.ie)

**atc**

ELECTRICAL &  
MECHANICAL  
Heating & Ventilation Division

# Benefits of Heat Recovery Ventilation



- Healthy Home: less pollen, less allergies and less dust mites.
- Comfort: constant fresh air supply all day everyday.
- Helps limit and eliminate Radon build up.
- Energy Savings.
- Draught free home.
- Quieter home as windows can be kept closed.
- No individual fans extracting costly heated air directly outside.
- No fungal or mould growth in bathrooms and bedrooms.
- No condensation on windows.
- Extra security as windows can be kept securely closed
- Enhanced house value after 2009, when BER certificates are mandatory

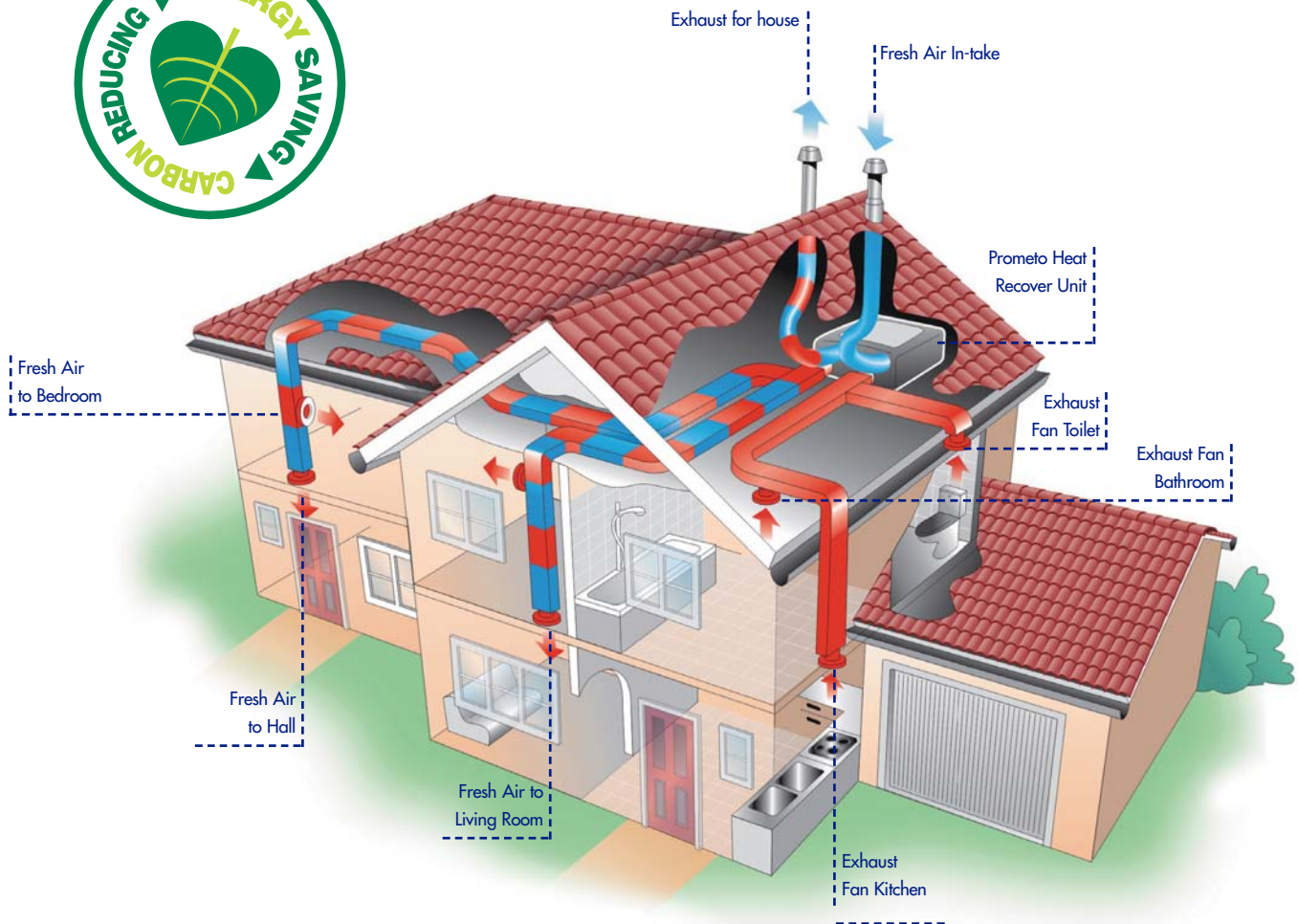

*"Its Cool to be Green"*

## Important Note

Whole house heat recovery ventilation by means of a heat recovery unit is not in itself a heating system. It recovers a percentage of the heat energy passing through it that would otherwise be wasted to the atmosphere.

# Prometeo HR400 - Sap Appendix Q Listed



The Standard Assessment Procedure (SAP) – Appendix Q data is the test results published by the independent test house, BRE UK for all Mechanical Ventilation Heat Recovery units.

This data is used by your Energy Assessor in conjunction with DEAP software to improve the energy rating of your dwelling in relation to BER Certification.

The BER certification is mandatory for all dwellings new or existing since January 1st 2009.

## Prometeo HR400 results for SAP calculations (at minimum flow rate condition)

This product has only been tested with rigid ductwork and the data are not applicable for SAP calculations if installed with flexible ductwork.

**Table Q2** – Systems with **rigid** ductwork only

Exhaust terminal configuration	Fan speed setting	Specific fan power (W/l/s)	Heat exchange efficiency (%)	Energy Saving Trust Best Practice Performance Compliant
Kitchen + 1 additional wet room	100% variable	0.57	92	Yes
Kitchen + 2 additional wet rooms	100% variable	0.54	91	Yes
Kitchen + 3 additional wet rooms	100% variable	0.56	90	Yes
Kitchen + 4 additional wet rooms	100% variable	0.63	90	Yes
Kitchen + 5 additional wet rooms	100% variable	0.67	89	Yes
Kitchen + 6 additional wet rooms	100% variable	0.76	88	Yes
Kitchen + 7 additional wet rooms	100% variable	0.85	88	Yes
Kitchen + 8 additional wet rooms	100% variable	0.98	87	Yes

## Dimensions

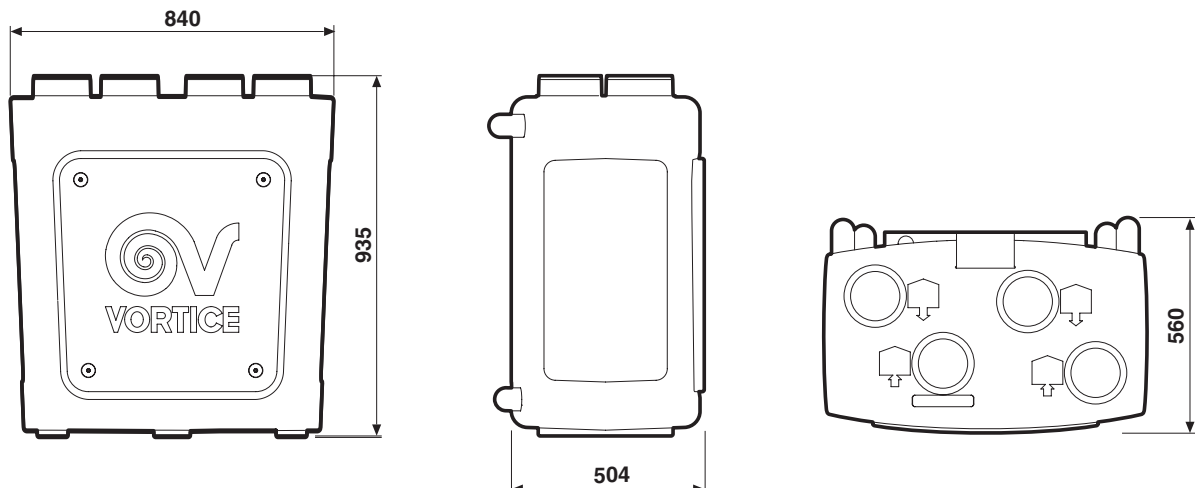

# Heat Recovery Ventilation



## PROMETEO HR400

The Prometeo HR400 heat recovery unit is a high efficiency heat recovery unit. It operates with a sophisticated counter-flow heat exchanger which recovers up to 92% of the heat passing through it that would otherwise be wasted to the atmosphere.

The HR400 operates at the equivalent power of a 10 – 14 watt energy light bulb at normal running speed.

### PROMETEO HEAT RECOVERY UNIT

CODE	DESCRIPTION
11815	PROMETEO HEAT RECOVERY UNIT HR400

### CONTROLS

CODE	DESCRIPTION
22313	RF REMOTE CONTROLLER WHITE
22315	EXTERNAL RF RECEIVER MODULE

An additional remote-controlled radio frequency RF device including a connection cable is available as an optional accessory and allows control of the appliance even if the position chosen for its installation is shielded from radio waves.



External RF receiver Module

### FILTER BOX AND FILTERS

CODE	DESCRIPTION
22329	F5 EXTERNAL FILTER BOX

Galvanised filter box (F5) designed to simplify maintaining the VORT PROMETEO HR 400. The filter box is fitted to the outside of the appliance and protects the intake and outlet ducts serving various rooms (replacing standard filters). Time spent on maintenance is less (thanks to a specially sized filter that gives constant filtering characteristics even when the unit is used for long periods), and maintenance work is simplified as direct access to the Prometeo unit is not required.



External Filter Box

22342	F5 DUST FILTER FOR EXTERNAL FILTER BOX
22321	F5 DUST FILTER FOR HR400 HRU
22323	F7 POLLEN FILTER FOR HR400 HRU

### PRE-HEATING BOX

CODE	DESCRIPTION
22317	PRE-HEATING BOX 500W 150mm

When the temperature and relative humidity of air entering and leaving the Prometeo unit are such that frost may form on the heat exchanger surface, this can affect the efficiency of the unit. It can also affect the completely automatic system in the VORT PROMETEO HR 400 that manages changes in fan speeds that, in the vast majority of cases, allow defrosting to be carried out. In particularly harsh climates, this may not solve the problem. In such cases, Vortice recommend the installation of a 500 W heater on the air intake duct so that incoming air can be warmed. This heater will operate automatically for the minimum time needed and will ensure the problem of frosting is solved.



Pre-Heating Box

**Rigid & Anti-bacterial ducting and accessories available ex-stock**



Ceiling Valve



Easi-Vent 204 Range

## THE FEATURES OF PROMETEO HR400

- SAP Appendix Q Eligible up to 92% efficiency
- Approved for extract from Kitchen + 8 Wet rooms in Dwelling
- Can be mounted vertically or horizontally
- Fitted with PE (polyethylene) Counter Flow Heat Exchanger
- Fitted with centrifugal fans with DC brushless energy efficient motors
- Fitted with F5 Filters on the Fresh Air inlet and Extract
- Optional F7 filters for additional protection against impurities available
- Built-in Frost Protection
- Built-in Summer By-Pass
- Supplied with RF Controller, displays Working Mode, Speed Setting, Timer Setting, Average Temperature, Relative Humidity, CO<sub>2</sub> levels, Time and Date. Also incorporates Filter change indicator and Fault indicator
- Fully automatic, manual forced summer by pass or full manual control at the press of a button
- Adjustable humidity and CO<sub>2</sub> settings
- Complies with 2008 Part F – Ventilation Building Regulations
- Easy maintenance for changing Filters or cleaning Heat Exchanger
- Guaranteed for 2 Years



HR 400



RF Remote Controller

## INDICATIVE RUNNING COST OF PROMETEO HR400

It is very difficult to give exact costs of running the Prometeo in any house as there are very many variations in living styles and habits. However the example below will give an indicative idea of the cost of running the unit for a year.

### Example:

We have taken an average 3 Bedroom semi-detached house with a floor area of 110m<sup>2</sup> for the purposes of this example.

Assuming, specific fan power (SPF) of 0.54w/l/s from SAP Q table equates to 12watts per hour.

We are also assuming that the unit runs on Speed 1 for 22 hours a day and on the boost Speed for 2 hours a day. The calculation will be as follows.

$(12W \times 22h) + (21W \times 2h) = 306Wh/day$   
 $306Wh/day \times 365 = 112kWh/year$   
Assume kWh = € 0.15  
 $112kWh \times 0.15 = € 16.80$

## DESIGN FACILITY

We are committed to providing you with comprehensive technical support for all your Heat Recovery projects. We have recently upgraded our software capabilities with two new AutoCAD 2008 workstations. We are now in a position to offer you our most comprehensive design service yet. Our technical personnel have completed a Sustainable Energy Ireland (SEI) approved BER Assessor Training Course. This ensures our personnel now have knowledge of energy efficient design to the latest standards.

Our team have also attended courses on Central Extract and Heat Recovery System design, installation and commissioning. Our Projects Team have a wealth of experience and knowledge and are dedicated to working with Consulting Engineers, Architects, Developers and Contractors. We can advise you on all aspects of product selection, design and installation to ensure the best solution is achieved.

Distributed by



### atc ELECTRICAL & MECHANICAL

**Head Office & Showrooms:** atc House, Broomhill Drive, Tallaght, Dublin 24, Ireland.

Tel: 353 (1) 462 5111 Fax: 353 (1) 452 0887 Email: [sales@atc.ie](mailto:sales@atc.ie)

### Regional Office:

BT3 Business Centre, 10 Dargan Crescent, Duncure Road, Belfast, BT3 9JP.

Tel: 02890 781948 Mob: 078 3499 3412