



thermoscreens®

DESIGNER PHV RANGE AIR CURTAINS

INSTALLATION, OPERATION & MAINTENANCE INSTRUCTIONS



PLEASE READ THESE INSTRUCTIONS CAREFULLY BEFORE ATTEMPTING INSTALLATION

Thermoscreens Ltd
St. Mary's Road Nuneaton
Warwickshire England
CV11 5AU

Email: sales@thermoscreens.com
Tel: +44 (0) 24 7638 4646
Fax: +44 (0) 24 7638 8578
www.thermoscreens.com



UN-PACKING YOUR DESIGNER PHV AIR CURTAIN

The following items are supplied and packaged within the boxes.

■ Designer PHV Air Curtain

Horizontal or Vertical Designer PHV Air Curtain plus fitting

■ Remote Control



■ Accessories

Spare M4 socket button screws
2.5mm hexagon key wrench
Fixing kits (if applicable)
RJ extension lead (vertical unit)

If anything is missing or damaged please contact your place of purchase immediately.

For your records

Date of Purchase.....
Place of Purchase.....
Serial Number.....

For warranty purposes proof of purchase is necessary so please keep a copy of your invoice.

(All documentation supplied with each unit should be stored and kept for future reference).

INSTALLATION OF YOUR HORIZONTAL APPLICATION DESIGNER PHV AIR CURTAIN

The Designer air curtain should be surface mounted inside the doorway and not exposed to the external environment or moist conditions. It should not be built-in or recessed in any way.

■ Location

Ensure that the unit is mounted within its height specification of 1.8m to 3.5m maximum (from floor level to the underside of the unit) with the air discharge grille positioned nearest to the door. The air curtain should be located as close to the door opening as possible for best performance, obstructions such as door opening devices, structural beams etc will reduce the efficiency of the air curtain. There must be at least 200mm clearance at the air inlet for air to enter the unit, see Figure 1 and Figure 2.

For maximum effectiveness it is essential to ensure the width of the air curtain is slightly wider than the width of the door when it is open.

Using the 2.5mm hexagon key wrench supplied, unfasten and remove all the casing screws from the Designer unit and carefully detach both sections of the casing. All screws should be kept safe as they will be required later in the installation.

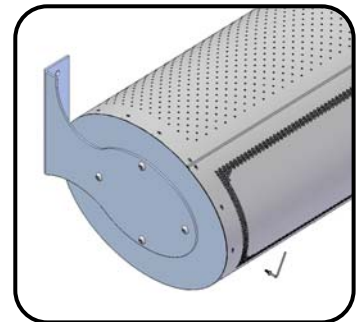

■ Wall and Ceiling Fixing

Before fitting the unit to the wall or ceiling ensure suitable wall fixing bolts are used, taking into account wall or ceiling type and unit weight (see Table 1)*.

Designer PHV horizontal air curtains are supplied with two stainless steel wall or ceiling brackets fitted to each end of the unit. Refer to Figure 1 for wall mounting details and Figure 2 for ceiling mounting details. Ensure all fixings are correctly fitted and securely tightened.

For multiple air curtains joined together over a doorway an additional wall bracket (T6811940) or ceiling bracket (T6811950) must be fitted at each joining point.

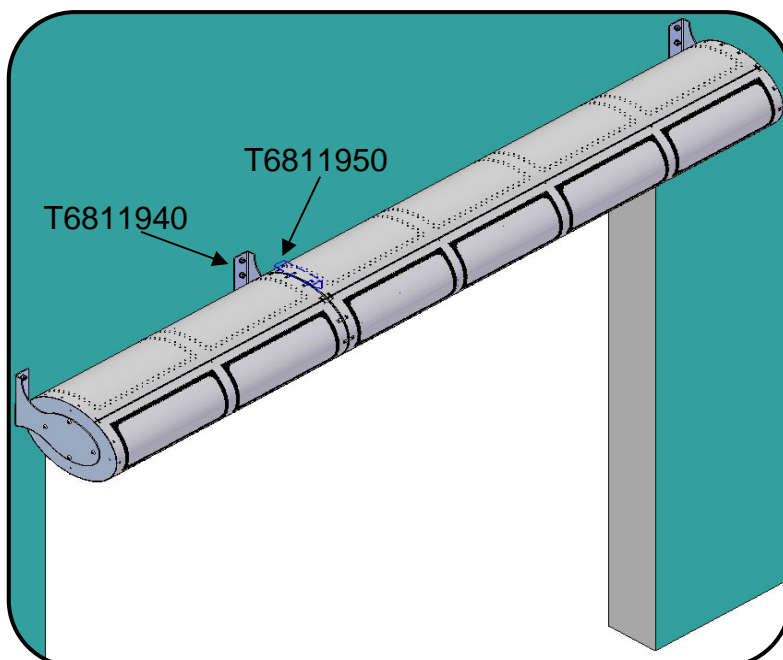
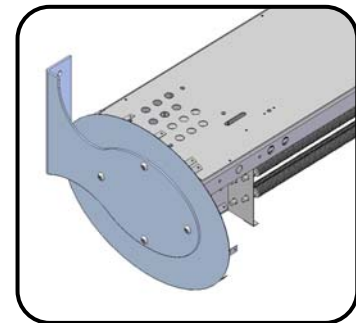

Back and inlet grille panels should only be fitted after all functional tests have been completed and verified (See Commissioning).

* It is the sole responsibility of the installer to ensure that all the fixing points and suspension system used are suitable for the air curtain being installed.

Attention: For stainless steel units the inlet grille and back panels are coated in an easy to peel protective film. Please ensure all the protective film is removed before the air curtain is put into service.

HORIZONTAL DESIGNER PHV AIR CURTAIN – Wall Mounted

Figure 1

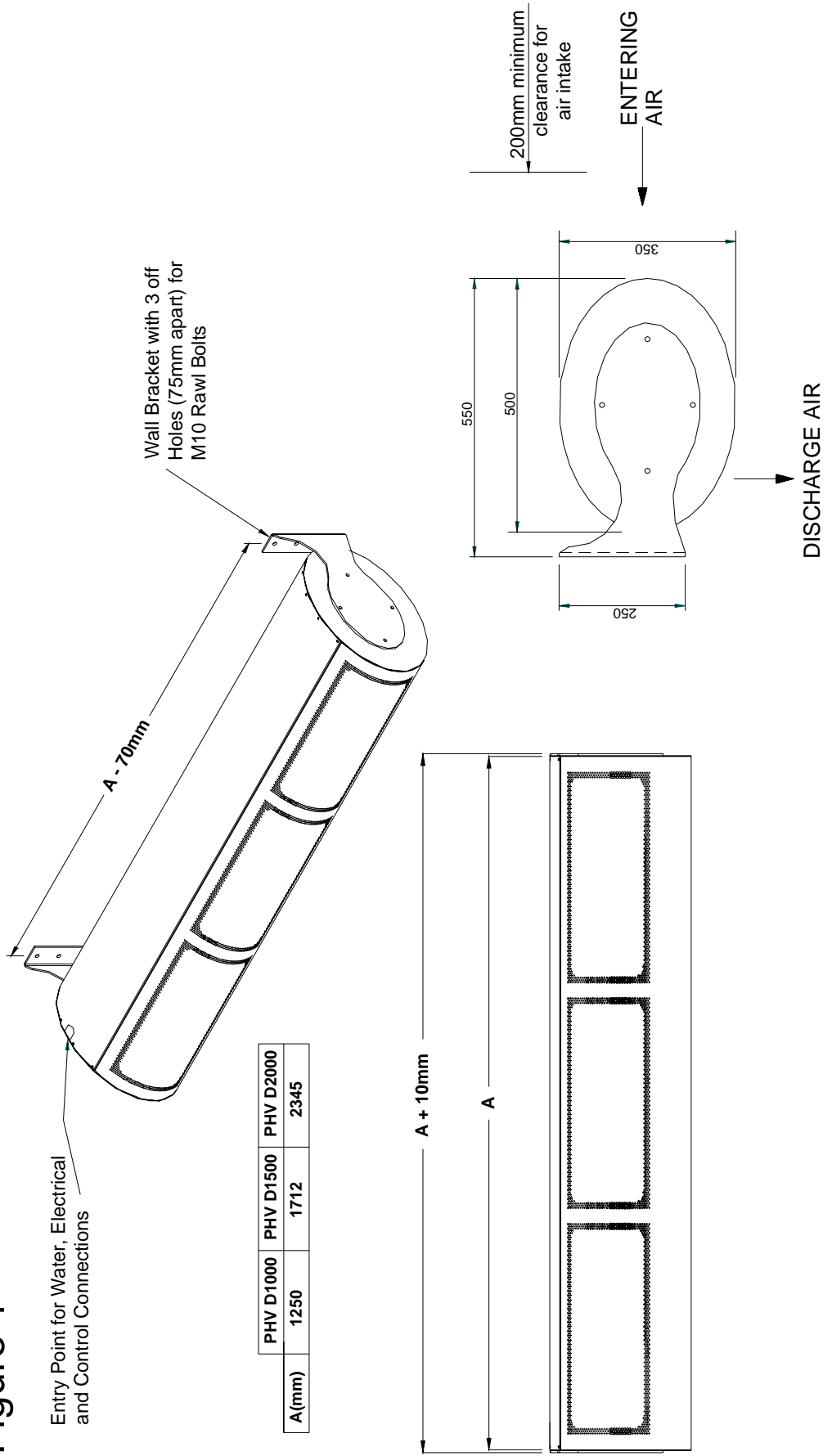

A (mm)	PHV D1000	PHV D1500	PHV D2000
1250	1712	2345	

HORIZONTAL DESIGNER PHV AIR CURTAIN - Ceiling Mounted

Figure 2

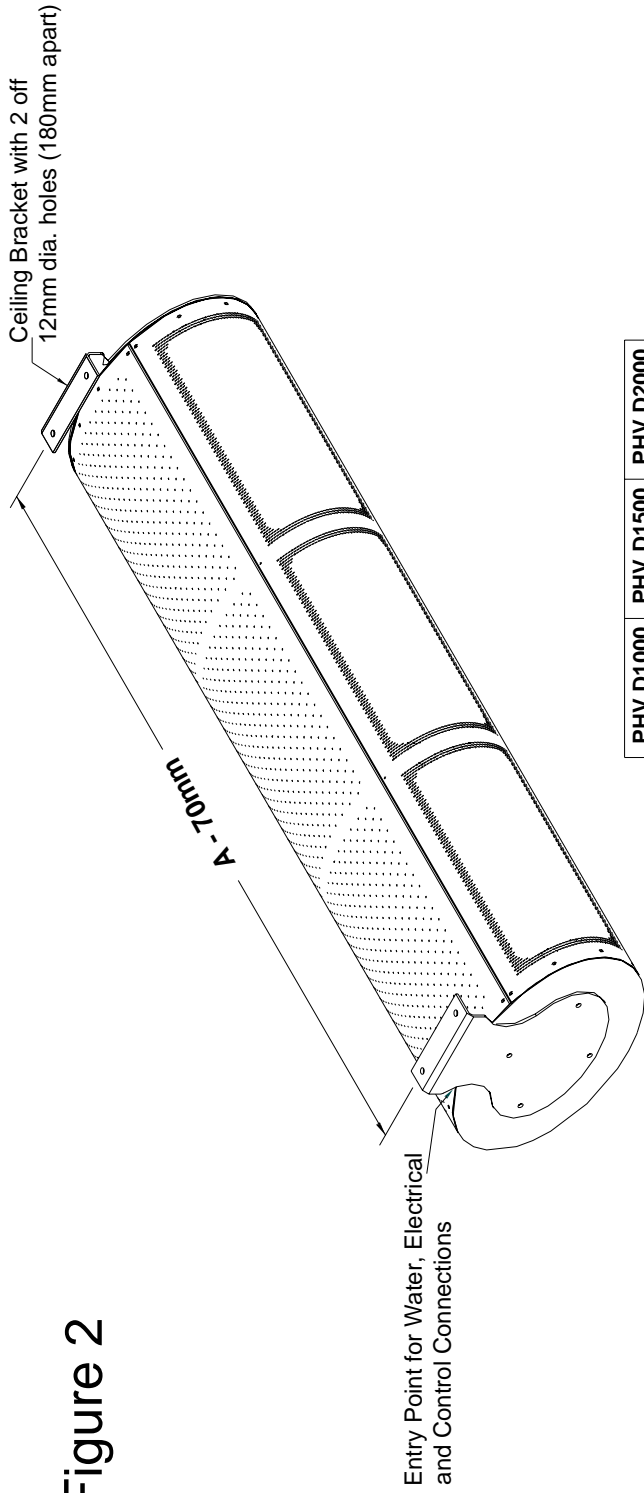

PHV D1000	PHV D1500	PHV D2000
A(mm)	1250	1712
		2345

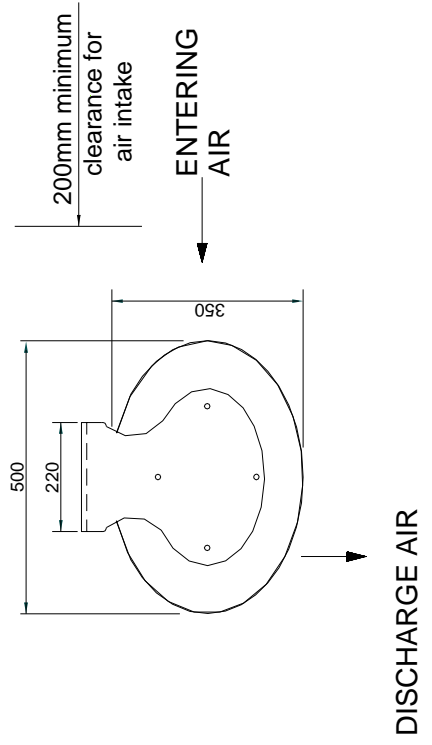
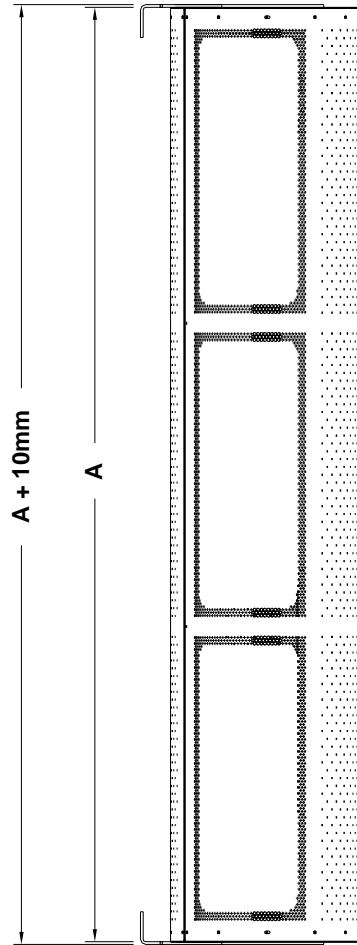

INSTALLATION OF YOUR VERTICAL APPLICATION DESIGNER PHV AIR CURTAIN

The air curtain must be surface mounted within the building and not exposed to the external environment or moist conditions. Do not install the air curtain in a doorway situation where there is a likelihood, or there has been a history of, rain ingress. The air curtain must not be built into a compartment or recessed.

■ Location

Prior to commencing any vertical installation it is essential to ensure the correct handing has been selected, i.e. Left Hand (LH) or Right Hand (RH) - . see "Handing Guide" in Figure 3. Maximum doorway width = 2.5m per air curtain.

For maximum effectiveness it is essential to ensure the height of the air curtain is slightly higher than the opening height of the door. Obstructions such as door opening devices, structural beams etc will reduce the efficiency of the air curtain. There must be at least 200mm clearance at the air inlet for air to enter the unit, see Figure 3.

■ Floor Fixing

Using the 2.5mm hexagon key wrench supplied, unfasten and remove all the casing screws from the Designer PHV unit and carefully detach both sections of casing. All screws should be kept safe as they will be required later in the installation.

Before installing the Designer unit obtain four suitable fixing bolts, taking into account floor type and unit weight (see Table 1)*. Rawlplug[®] M10 Projecting Rawlbolt[®] 44356 type may be suitable. For dimensional details refer to the general assembly drawing, Figure 3.

Designer PHV vertical air curtains are supplied with the base plate fitted. Determine and place the unit at its most favourable position. A wall bracket must be fitted to the top of the unit for D2500V and D3000V stacked air curtains to tether the top of the unit to the wall.

In order to use the wall bracket supplied ensure the back of the base plate is no more than 25mm away from the wall. If skirting board, with maximum depth of 25mm is fitted, ensure the back of the base plate is touching the skirting board.

Using the base plate as a template, mark the location of the four holes, as indicated in the adjacent picture. Using a suitable masonry drill bit, correctly drill the four marked out holes. Place M10 fixing bolts into each hole, ensuring all bolts are upright.

Reposition the air curtain base plate over the projecting bolts. Tighten each M10 nut as indicated in the adjacent picture. Ensure the vertical unit is secure, upright and square.

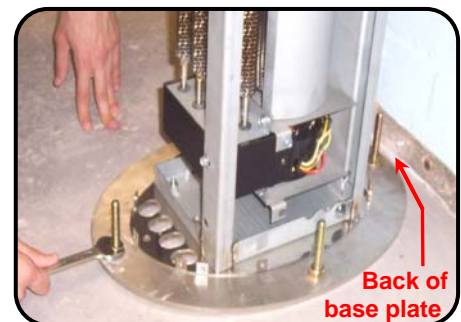

Using a hacksaw carefully cut the projecting bolts flush with the nut, ensuring the base plate is not damaged or marked in any way.

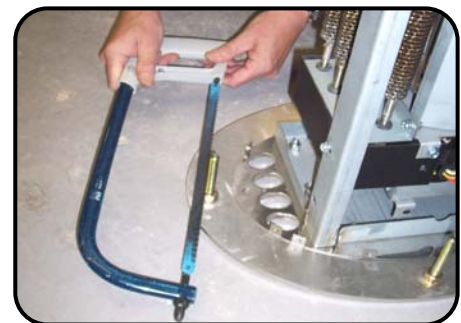

Remove only one M10 nut and refit and secure bolt with a stainless steel M10 dome nut supplied. Repeat for each of the other three projecting bolts one at a time.

Both sections of the casing should be fitted only after all functional tests have been completed and verified (see Commissioning).

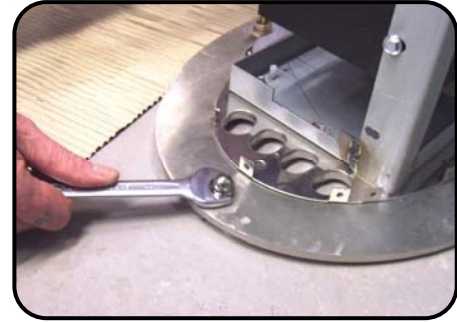

✚ Stacking Air Curtains

Only a single 1.0m stacking vertical air curtain should be mounted on top of another vertical unit.

Using fixing kit components supplied, the vertical stack frames are joined together using four M8 x 35mm hexagonal bolts and M8 nuts (see insert). Feed each hexagonal bolt from the top unit and fasten with M8 nuts. All stacked units must be secured with a wall bracket at the top of the stack, refer to Figure 3.

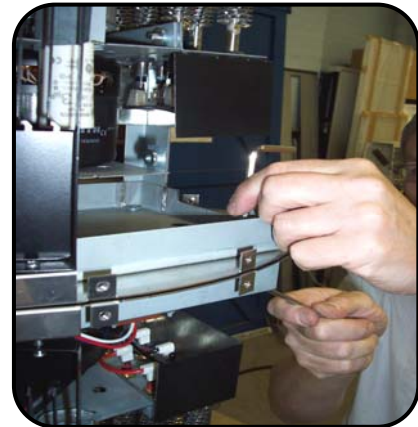

* It is the sole responsibility of the installer to ensure that all the fixing points and suspension system used are suitable for the air curtain being installed.

Attention: For stainless steel units both sections of the casing are coated in an easy to peel protective film. Please ensure all the protective film is removed before the air curtain is put into service.

✚ Safety and Electrical Connections

All electrical wiring and connections MUST be carried out by a competent qualified electrician in accordance with the latest edition of the IEE wiring regulations and/or local statutory regulations.

- ✚ A single phase or 3 phase local isolator with a contact separation of at least 3mm on all poles must be fitted in the electrical supply wiring to the air curtain located in an accessible position.
- ✚ The air curtain must be earthed.
- ✚ The appliance must be connected using cables having an appropriate temperature rating (heat resistant). For two air curtains in a stack, electrical power must be connected separately to the bottom air curtain and to the top air curtain.
- ✚ Ensure that the supply cables, circuit breakers and other electrical installation equipment are correctly sized for the air curtain being installed; see Table 1 for Power Ratings. See also data badge inside of unit adjacent to electrical inlet.
- ✚ On a 3 phase electrical supply the unit requires a neutral connection (3N~).
- ✚ Cable glands used for the Electrical Input must be rated IP21 or higher.

VERTICAL DESIGNER AIR CURTAIN

Figure 3

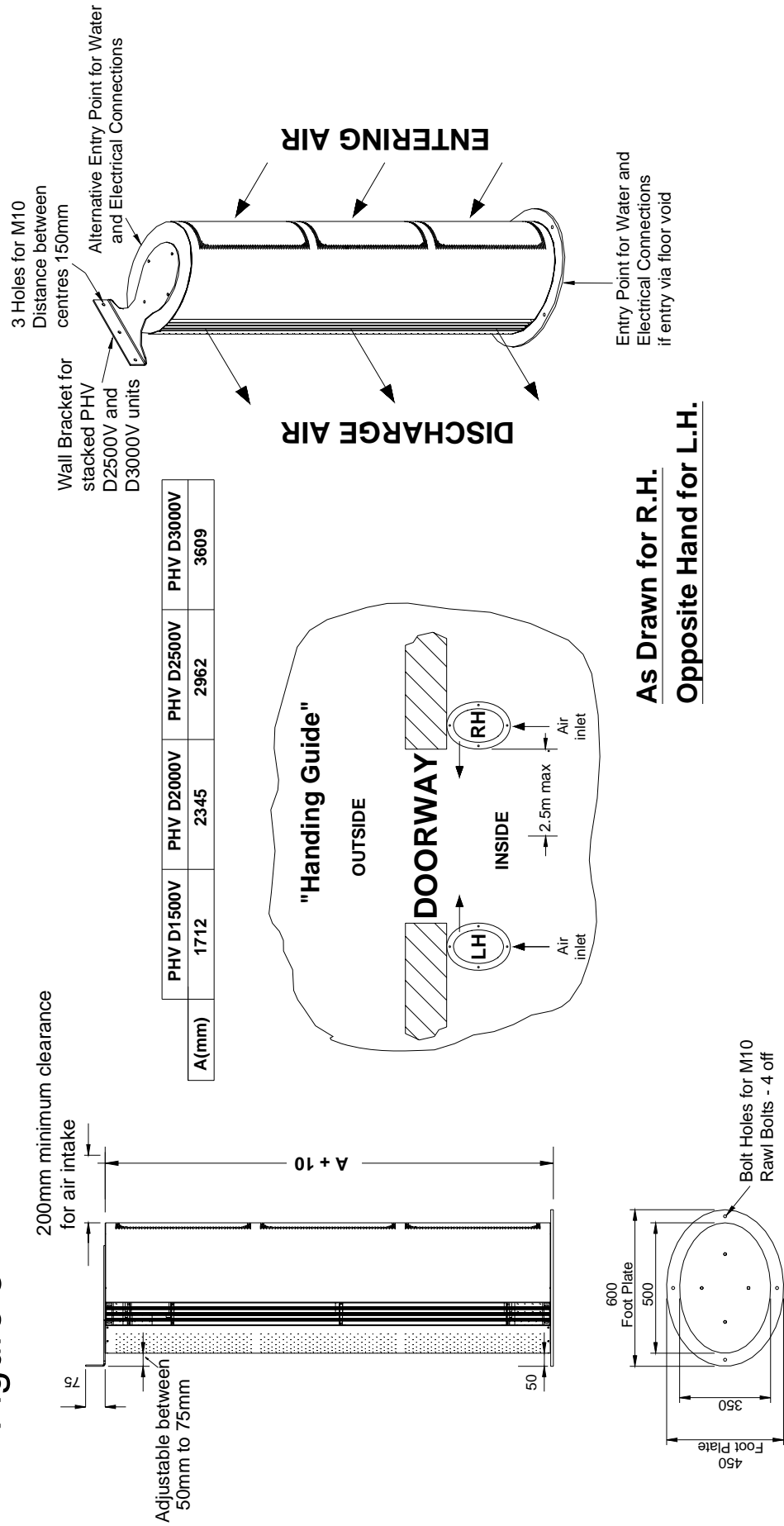

Table 1

Air Curtain		Electrical Supply (V/ph/Hz)	Rated Power Input (kW)	Current per phase (A)	Heat Output (kW)	Weight (kg)
PHV D1000A		230/1/50	0.30	1.5	N/A	54
PHV D1500A, PHV D1500A V		230/1/50	0.40	2.0	N/A	67
PHV D2000A, PHV D2000A V		230/1/50	0.60	2.9	N/A	93
PHV D2500A V (Stacked Unit)	Top air curtain	230/1/50	0.30	1.5	N/A	121
	Bottom air curtain	230/1/50	0.40	2.0	N/A	
PHV D3000A V (Stacked Unit)	Top air curtain	230/1/50	0.30	1.5	N/A	147
	Bottom air curtain	230/1/50	0.60	2.9	N/A	
PHV D1000W		230/1/50	0.30	1.3	12.0	61
PHV D1500W, PHV D1500W V		230/1/50	0.40	1.8	18.0	82
PHV D2000W, PHV D2000W V		230/1/50	0.60	2.7	24.0	107
PHV D2500W V (Stacked Unit)	Top air curtain	230/1/50	0.30	1.3	12.0	143
	Bottom air curtain	230/1/50	0.40	1.8	18.0	
PHV D3000W V (Stacked Unit)	Top air curtain	230/1/50	0.30	1.3	12.0	168
	Bottom air curtain	230/1/50	0.60	2.7	24.0	
PHV D1000E		400/3/50	12.30	18.7	6.0/12.0	57
PHV D1500E, PHV D1500E V		400/3/50	18.40	27.9	9.0/18.0	71
PHV D2000E, PHV D2000E V		400/3/50	24.60	37.5	12.0/24.0	99
PHV D2500E V (Stacked Unit)	Top air curtain	400/3/50	12.30	18.7	6.0/12.0	128
	Bottom air curtain	400/3/50	18.40	27.9	9.0/18.0	
PHV D3000E V (Stacked Unit)	Top air curtain	400/3/50	12.30	18.7	6.0/12.0	156
	Bottom air curtain	400/3/50	24.60	37.5	12.0/24.0	

Weights include 6kg for hanging brackets used with a horizontal overdoor unit. Plinth Base for vertical unit weights 16kg. Vertical stacked units require a top support wall bracket which weighs 3kg.

■ LPHW Models

For LPHW models ensure suitable water mains isolation valves, as detailed below, are fitted to both the flow and return pipework.

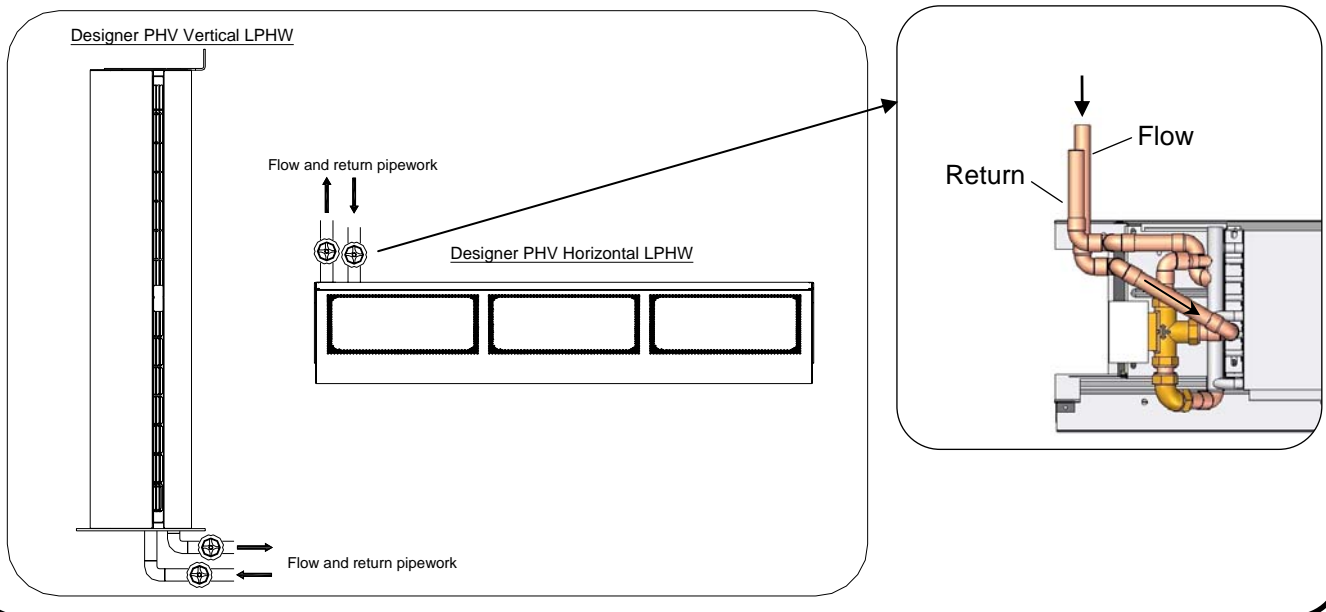

Removable connection after the isolating valves must be used for the flow and return pipes to allow easy removal of the 3 port valve. For the Designer PHV the 3 port valve(s) is fitted inside the air curtain.

Air Curtain		Water Flow Rate (l/s) 82/72 °C	Coil + Valve Water Pressure Drop (kPa)
PHV D1000W		0.30	6.6
PHV D1500W, PHV D1500W V		0.43	14.3
PHV D2000W, PHV D2000W V		0.57	28.6
PHV D2500W V (Stacked Unit)	Top air curtain	0.30	6.6
	Bottom air curtain	0.43	14.3
PHV D3000W V (Stacked Unit)	Top air curtain	0.30	6.6
	Bottom air curtain	0.57	28.6

■ Fitting/Connecting the Ecopower Remote Control

The remote control unit should be located in a suitable place for easy access, it can be fixed to the wall via two key-hole slots. Drill and fix the screws into the wall leaving a small gap between the head and the wall, lower the unit onto the screws, for fixing centres see adjacent figure. Ensure suitable fixing screws are used.

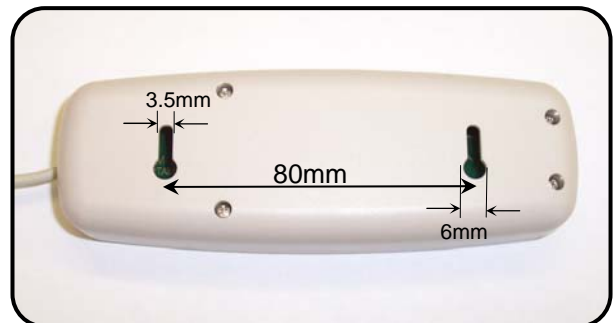

The remote control is supplied with 3m of cable and a pre-fitted RJ connecting plug. Ensure the remote control cable is safely secured and connected.

■ Multiple Installation

To Master/Slave two or more air curtains together, or if there are two air curtains in a vertical stack, the remote control is plugged into the first unit (the Master) and a RJ extension lead then connected from the Master to the Slave unit(s).

For horizontal and vertical Master/Slave configuration an independent mains supply as per Table 1 must be supplied to each air curtain. Horizontal application air curtains, up to a maximum of eight units, may be connected as indicated below. Thermoscreens 3m RJ extension leads are available and should be ordered separately.

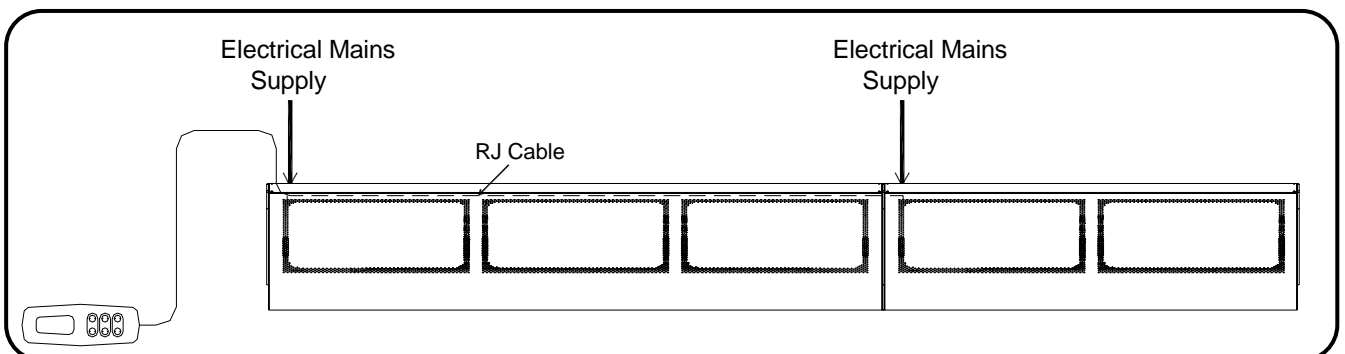

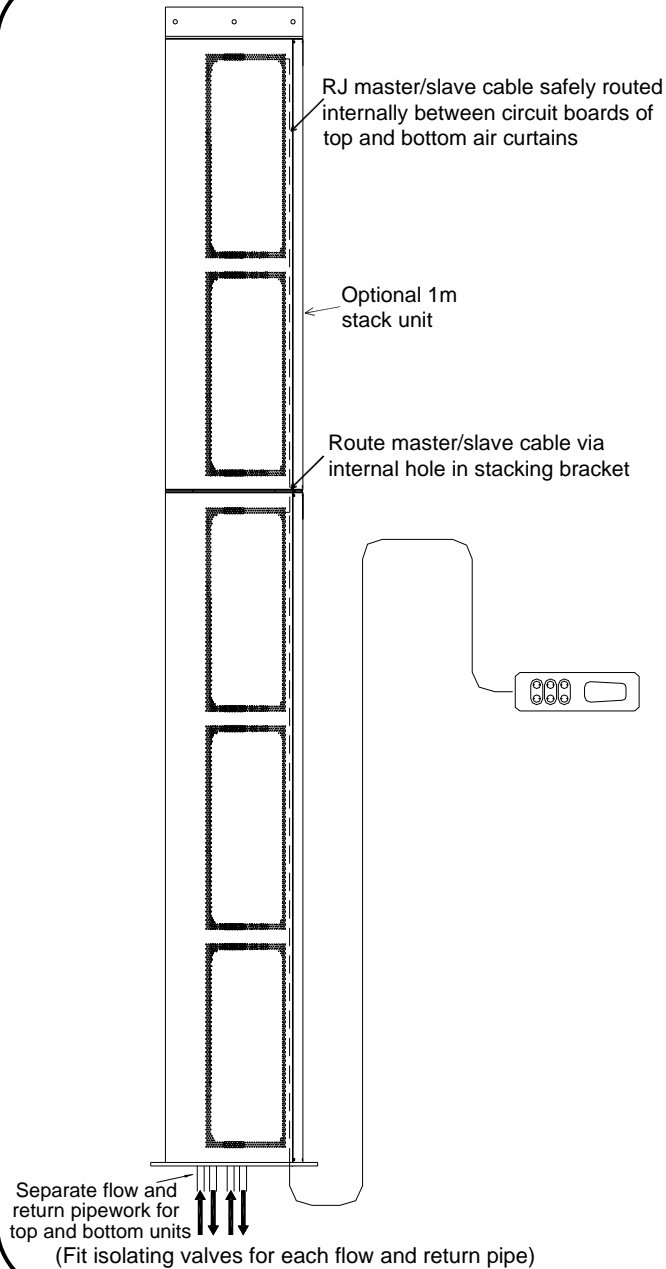

Each Designer PHV LPHW is fitted with the 3 port valve inside the casing of the air curtain. For two air curtains in a stack each air curtain requires separate and independent water flow and return connection.

In order to obtain optimum heat output, all air from the system and the heating coil must be vented.

Ecopower Controller Motherboard (v8)

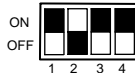
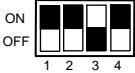
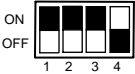
Function	Control	Comments	Standard
<p>Fan Heat Interlock for Electric Heated Air Curtains– The heat output is dependent on the fan speed. If low or medium fan speed is selected the heat output can only go up to first heat stage. Only if the unit is operating on high fan speed can the second heat stage be selected. This feature operates in manual or auto mode.</p>	<p>DIP1</p> 	<p>Maximum heat output achieved if maximum fan speed selected. Independently set-up DIP switch on each mother board.</p> <p>Used to avoid excessive temperatures with electric heated air curtains.</p>	<p>As supplied, for electric heated air curtains the default setting for heat output would be dependent on fan speed (DIP1 ON).</p> <p>For Ambient and LPHW heated air curtains default setting for DIP1 OFF.</p>
<p>Disable Fan Run-on for LPHW and Ambient Air Curtains – Disable fan run-on.</p>	<p>DIP2</p> 	<p>Must only be used for LPHW and Ambient air curtains. Independently set-up DIP switch on each mother board.</p>	<p>As supplied, for Ambient and LPHW heated air curtains the default setting would disable fan run-on (DIP2 ON).</p>
<p>Thermostat Master – Only the air sensor thermistor in the master air curtain will be used for measuring the reference air temperature for the whole master/slave installation.</p>	<p>DIP3 Option</p> 	<p>The air sensor thermistors in all the slave air curtains will be ignored. This will then avoid situations on larger doorways with master/slave air curtains where some units can blow cold air whilst others can blow warm air, because they currently all refer to their own air sensor for control of the heat output of each air curtain.</p> <p>The master air curtain need not be the one that the wall control is plugged into. This dip switch setting must also be used for Global Switching (Master/Slave) via the INHIBIT terminal – see next page.</p>	<p>As supplied, the default setting would be for the air sensor thermistor on all units to be measuring (DIP3 OFF).</p>
<p>Overheat Fan Disable – If DIP4 is on and thermal overheat trips, heat and fan circuits are isolated and LED's on wall switch flash. If DIP4 is off and TOC trips out, only the heat circuit is isolated and the LED's on the wall switch flash.</p>	<p>DIP4 Option (Electric only)</p> 	<p>Wall switch upgrade required. The handset has to be powered on. Independently set-up DIP switch on each mother board.</p> <p><i>To remove fault, isolate electrical supply to air curtain, reset TOC and reconnect supply.</i></p>	<p>As supplied, the default setting would enable fan if TOC trips (DIP4 OFF). <i>NB: If TOC operates with an upgraded switch the LED's on switch flash, regardless of DIP4 settings.</i></p>
<p>Retain User Settings (toggle) – If electrical supply to the air curtain is removed, upon restoring electrical supply the customer's settings on the remote control will be retained, i.e. if unit were operating beforehand, it would automatically start up again and operate on the exact same settings as before.</p>	<p>Optional feature –via secret key press (Fan-down)</p>	<p>Wall switch upgrade required. <i>To toggle – switch unit on from handset. Hold Auto button till Auto LED flashes. Press fan down button to toggle selection.</i></p>	<p>As supplied, the default setting would be for the unit to start up again automatically. Need to do the secret key presses to revert back to “nothing happens” when power is restored, as we have it now.</p>
<p>Fan run-on time set two minutes.</p>	<p>Built-in</p>	<p>If “FAN ONLY” has been selected, at switch off, no fan run-on.</p>	
<p>Reduce time for fan speeds to turn on and index up through Low, Medium and High fan speed when turning on via the BMS/Remote On/Off option.</p>	<p>Built-in</p>		

□ - white rectangle indicates the moveable head of each 4 way DIP switch

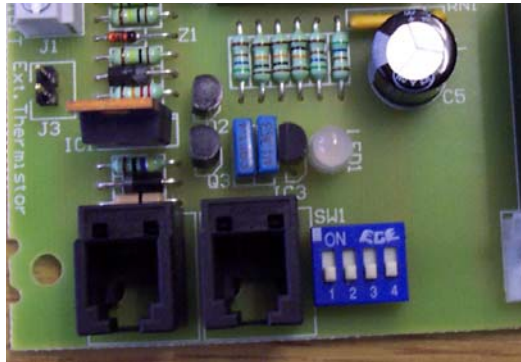

DIP switches fitted on the Ecopower board provide a selection of optional features as described above. Isolate and switch electrical power off before configuring and/or changing any DIP switch settings.

- Easy plug-in arrangement for remote air sensor thermistor on a 1m lead. Plugging-in the remote air sensor to J3 disables the standard air sensor thermistor already fitted on the Ecopower board. As supplied, the board will not have the remote air sensor fitted.

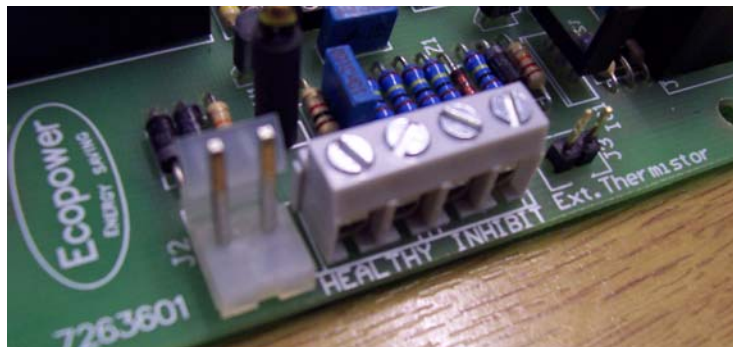

- An INHIBIT two screw terminal fitted on the Ecopower board for BMS remote On/Off feature. If the terminal is linked, i.e. by 2 wires to a remote volt free contact, the unit will run. If it is open circuit across the terminal the unit will switch off. This remote On/Off feature has global switching logic, i.e. if you master/slave several units together you need connect the remote contact to only one of them to turn all units on and off in the master/slave system. For global switching to work on the slave units, need to set DIP3 Option (see previous page) on the unit that the remote contact is wired to and have previously turned the unit on with the wall switch. As supplied, a wire link will be fitted to the terminal block on every unit. For summer settings place a 3.3kΩ resistance across the INHIBIT terminal, with these settings fans only will run even if controller is requesting for heat.

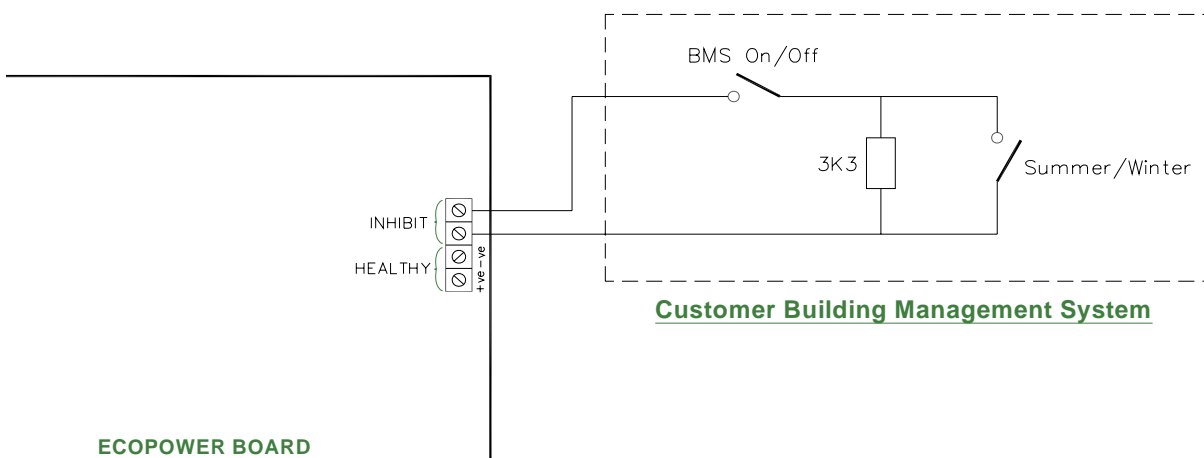

- A HEALTHY two screw terminal is included on the board for a fault signal indication if the electric elements overheat cut-out has operated. A healthy system provides a 24V DC signal at the terminals compared to an overheat fault which provides 0V DC.

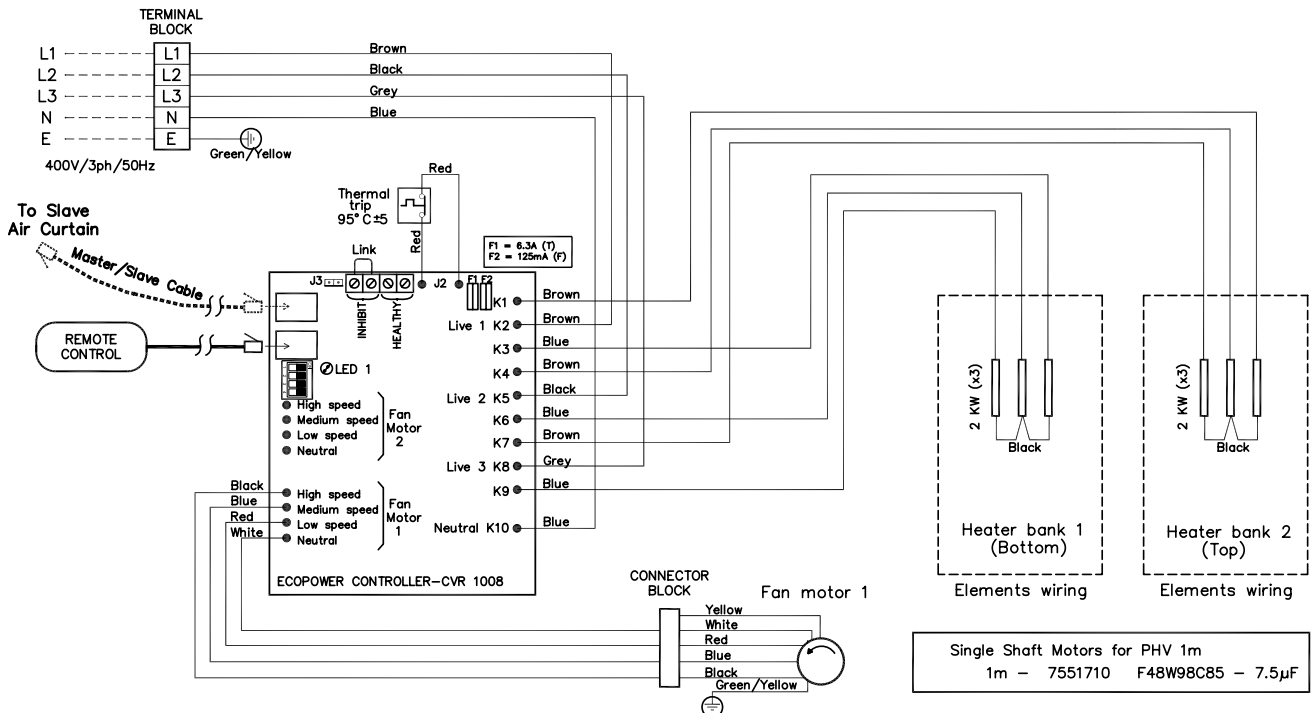

PHV D1000E and PHV D1000E V*

* used as top air curtain for vertical stacking only

Single Shaft Motors for PHV 1m
1m - 7551710 F48W98C85 - 7.5μF

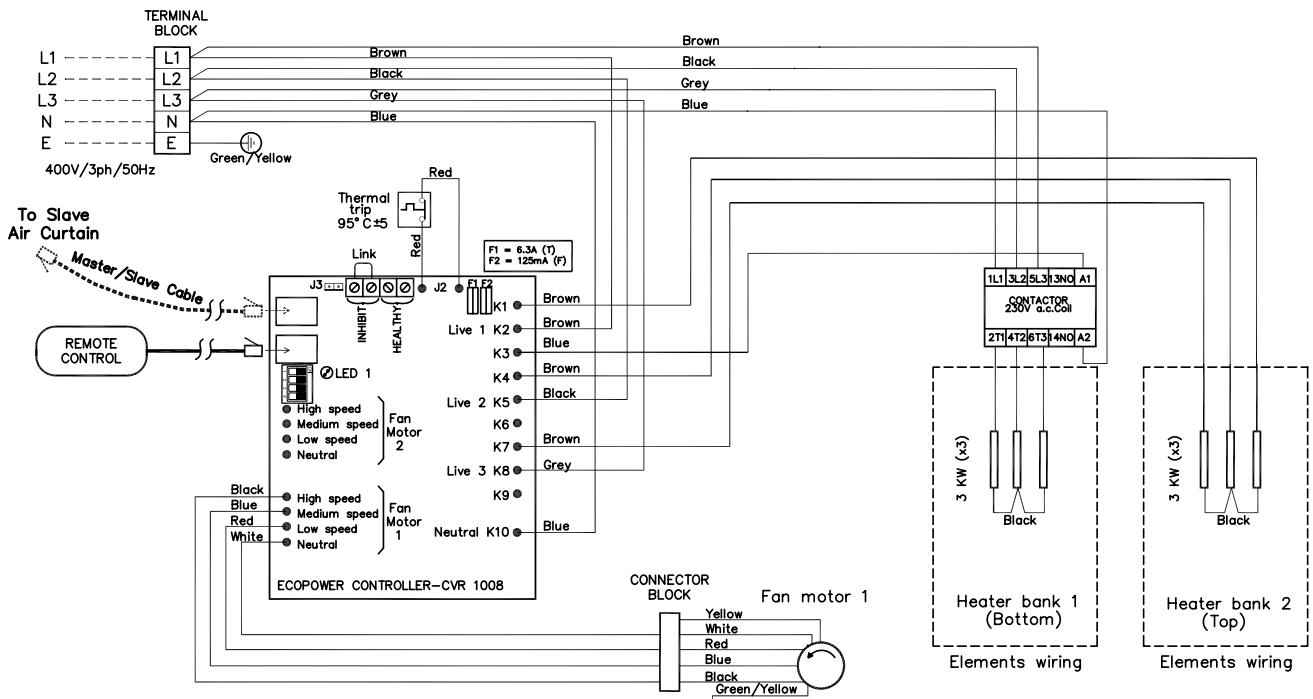

PHV D1500E and PHV D1500E V

Single Shaft Motors for PHV 1.5m
1.5m - 7551730 F48W94C85 - 7.5μF

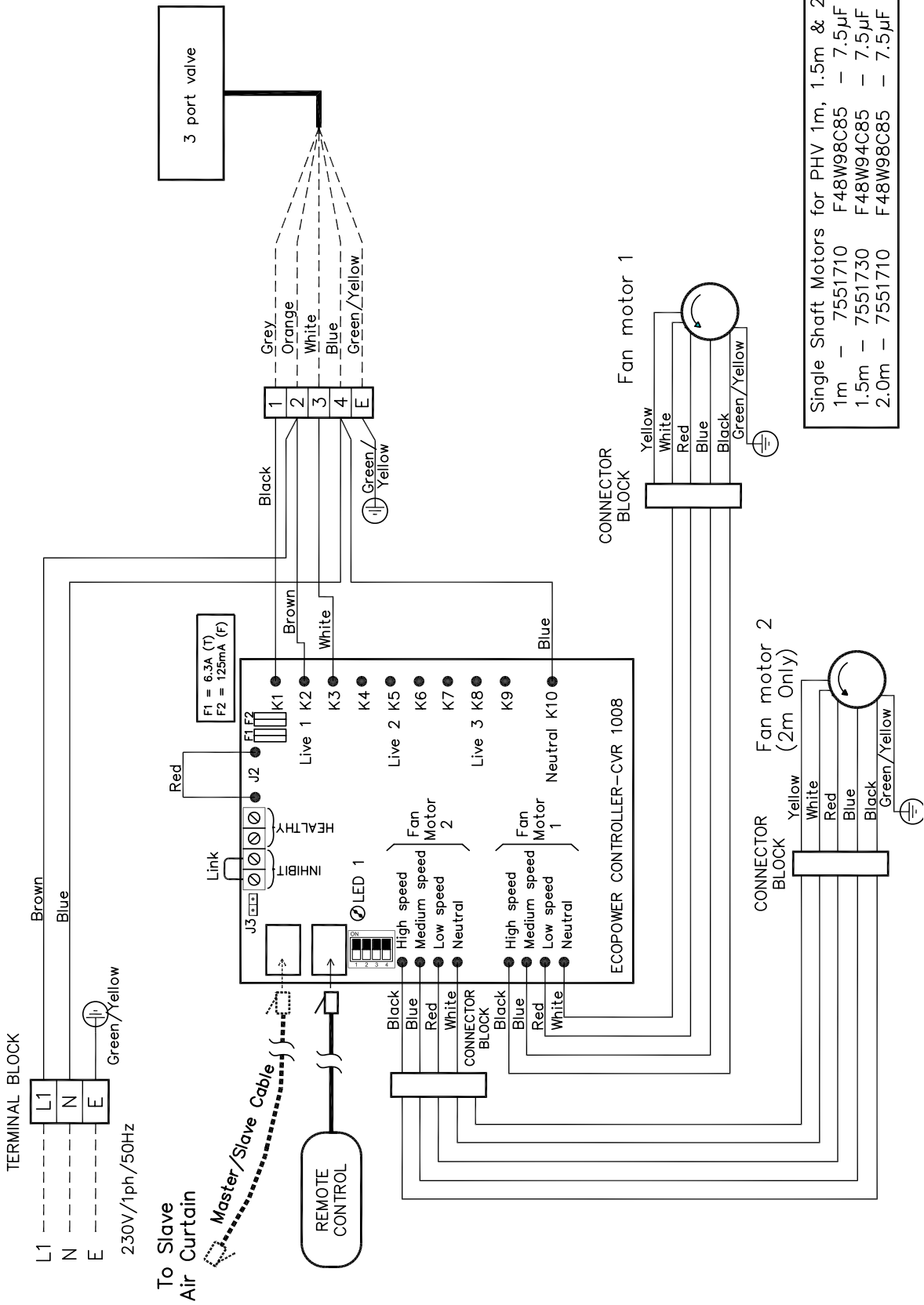

PHV D1000W, PHV D1500W, PHV D2000W, PHV D1000W V*, PHV D1500W V and PHV D2000W V

* used only as top air curtain for vertical stacking

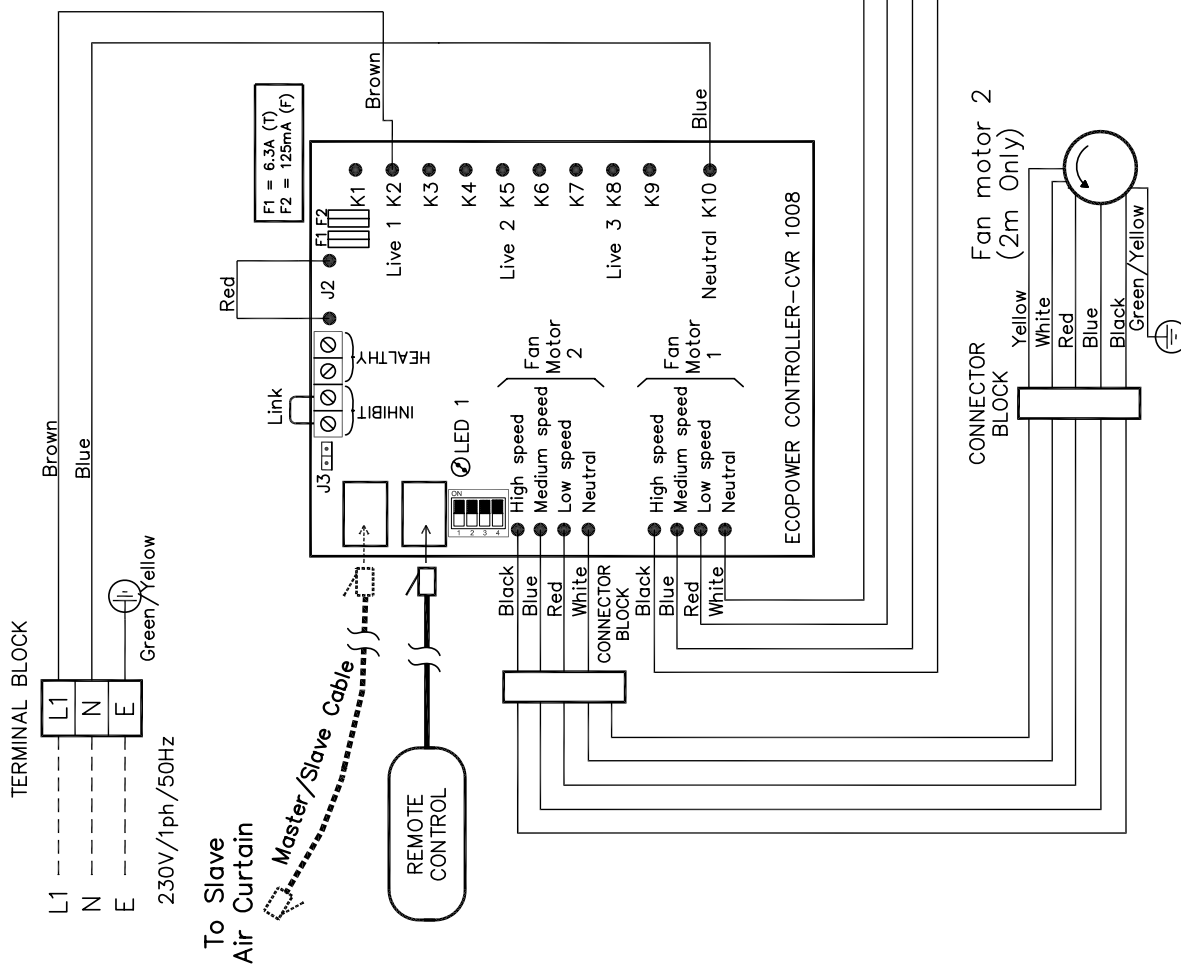

Single Shaft Motors for PHV 1m, 1.5m & 2m			
1m	-	7551710	F48W98C85 - 7.5µF
1.5m	-	7551730	F48W94C85 - 7.5µF
2.0m	-	7551710	F48W98C85 - 7.5µF (x2)

PHV D1000A, PHV D1500A, PHV D2000A, PHV D1000A V*, PHV D1500A V* and PHV D2000A V

* used only as top air curtain for vertical stacking

Ecopower Remote Control Operation

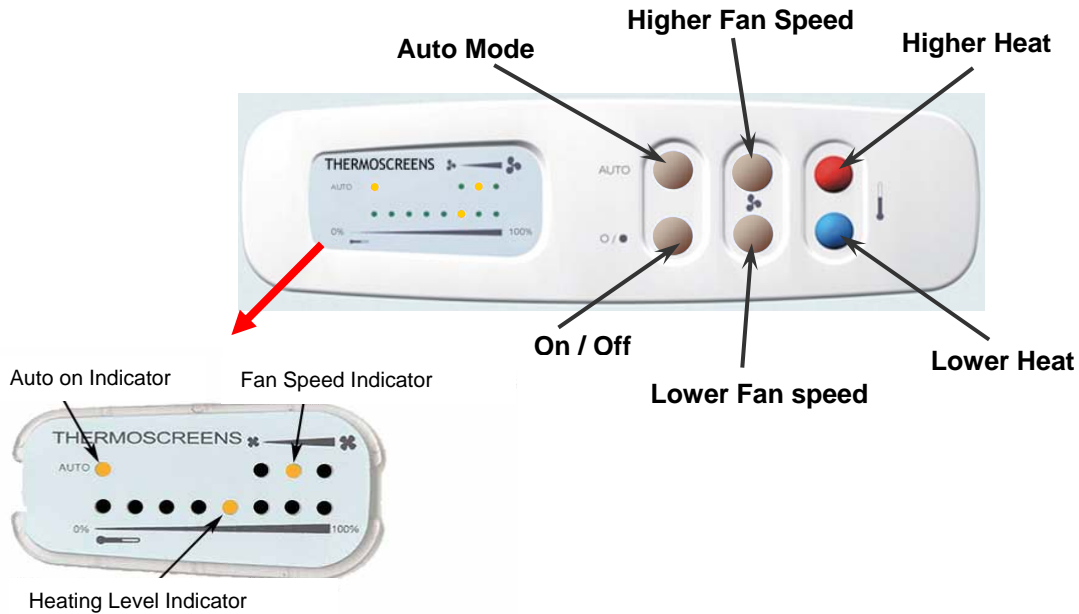

Push On/Off switch to turn On, then operate as follows :-

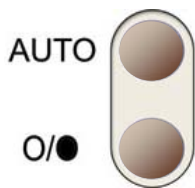

Auto Switches between manual and automatic heat regulation. The Auto on indicator LED is lit for "Auto Mode" and un-lit for "Manual Mode".

On/Off Turns the air curtain On or Off (when turned off the settings for heat and fan speed are retained). If the air curtain is heating when it is turned off with this switch the fan will run-on for a time (approx. 2 minute) to dissipate excess heat.

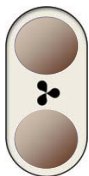

Selects the appropriate fan speed (Low, Medium or High) to suit the air curtain height and outside wind conditions. Fan speed can be changed when unit is in either Auto or Manual Modes. A fan speed indicator LED shows which fan speed is selected.

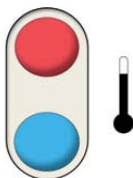

In "Auto Mode" the air curtain measures the incoming air temperature and automatically selects the necessary amount of heat to keep it at the level selected. Heating level indicator LED's go from 0% to 100% in 8 steps to show the level selected.

In "Manual Mode" heat output can be selected as Zero, Half Heat or Full Heat. Heating level indicator LED's go 0%, 50% or 100% to show the level selected.

Push On/Off switch again to turn Off

Note If the mains supply is isolated or cuts-out during operation the On/Off switch will need to be pushed again to start the air curtain when the mains supply is restored. The safety thermal cut-out in the air curtain may operate, if this happens it will need to be reset by a competent technician.

■ Commissioning

With the casing still removed confirm the air curtain fans operate correctly and there is no excessive mechanical noise coming from the fans. Check that the fans operate correctly at Low, Medium and High speeds. If the unit is electric heated or water heated check that the air stream from the discharge grille warms up across the whole length of the air curtain when heating is selected. Check that heating increases as higher heat is selected and feel to see that the warm air stream is reaching across the doorway with door open or closed. Verify the operation of the Ecopower controller in Manual Mode. Then select Auto Mode and increase the heating set point until the air stream warms up. Reduce the heating set point until the air stream goes cold.

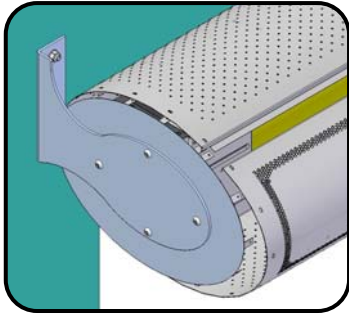

Once all functional tests have been carried out and the air curtain operates satisfactorily, hook and locate the back casing in between the two fixing tabs at each end of the air curtain (see insert). Follow up and mount the inlet casing in between the two fixing tabs ensuring all fixing holes are correctly aligned with tab inserts. Secure both panels using the M4 socket button screws supplied.

Before leaving site it is important that the air curtain installation is “Handed-Over” to the end user or his representative and the operation of it is fully explained and that they understand how it operates. Explain also the service intervals and that the unit must be regularly cleaned.

■ Fault Conditions

In the event of a fault with electrical heated air curtains the thermal cut out(s) may operate. *Note: If the mains supply is isolated during operation then the thermal cut outs may operate.* The thermal cut out(s) are located within the unit adjacent to the electric elements (one on the 1m & 1.5m and two on the 2m model), the position of each TOC is marked as per insert. There are two fuses on the Ecopower circuit board which may blow in the event of a fault. The Ecopower circuit board is located towards the top of each unit.



In the case of a fault condition (refer to flowchart) do not attempt to reset the thermal cut outs or replace the fuses. Arrange for a Thermoscreens appointed technician or certified electrician to attend the unit to investigate the reason why the thermal cut outs/fuse(s) have operated. Once the cause has been determined and rectified, they will reset/replace the thermal cut out/fuse and function test the unit.

■ PCB Status

Fitted on the PCB board inside of the air curtain is an LED shown as LED1 on wiring diagrams that will indicate the Ecopower control status.

1. LED flashing green – operation normal.
2. LED flashing red – low supply voltage.
3. LED permanently red – thermal cut outs open circuit (electrically heated models only).

Note to reset the thermal cut outs please refer to Fault Conditions section detailed above.

User Fault Finding Flowchart (for Ecopower Control)

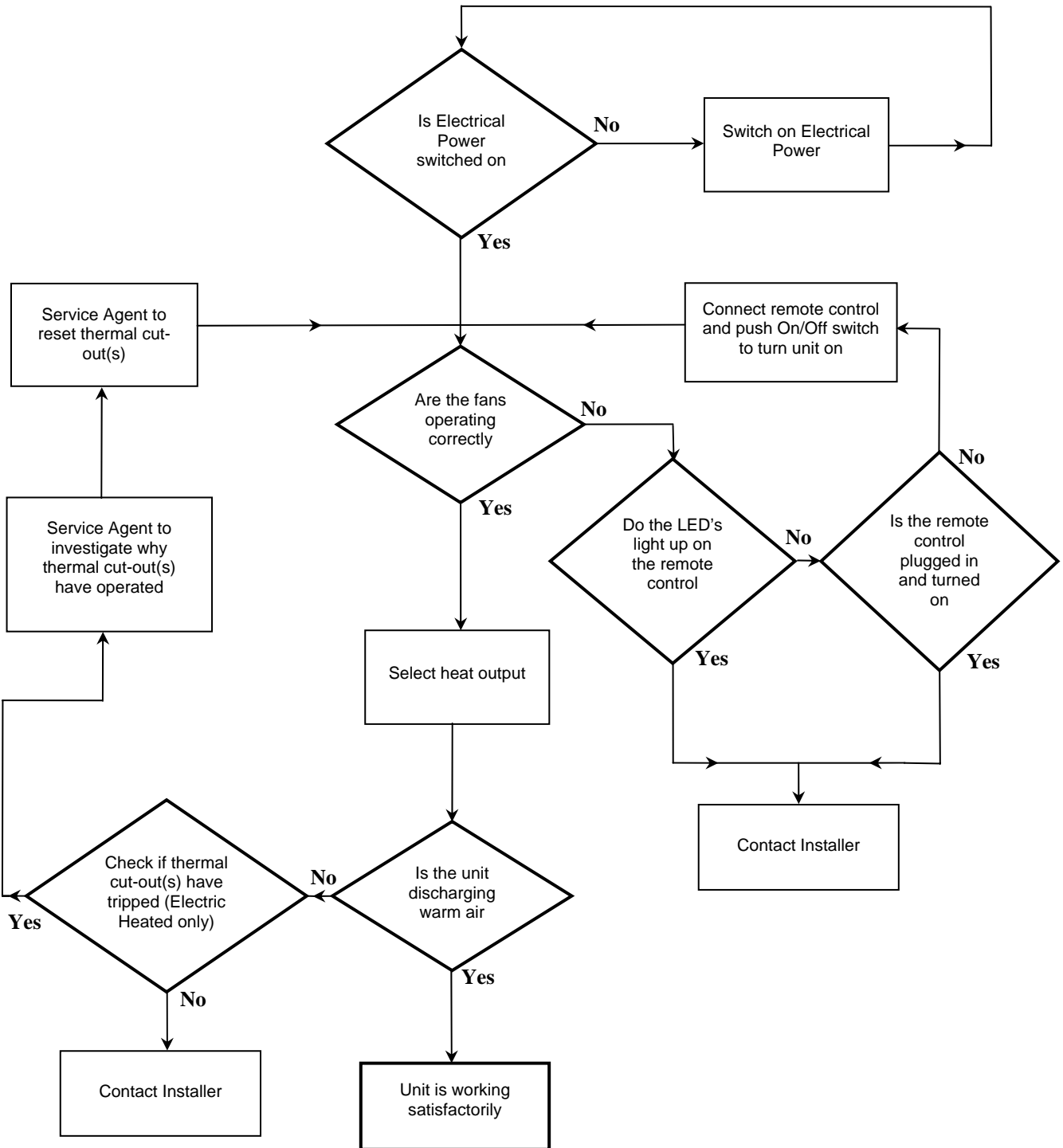

■ Service & Maintenance

Always disconnect and isolate the mains electricity supply before installing, maintaining or repairing this equipment. With 2.5m or 3m vertical air curtains there are two air curtains, one stacked on top of the other. Isolate the mains supply to both top and bottom air curtains. Note: All maintenance/repairs should only be carried out by a competent electrician or Thermoscreens appointed technician.

To ensure the air curtain operates at full efficiency the back and inlet grille panels, fan impellers, housings and motors must be kept free of dust and debris. Build up of dust on the fan impellers can cause vibration, noise and excessive wear on the motor bearings.

Frequency of cleaning will depend on the environment, but we would recommend that the unit be cleaned a minimum of every 3 months (failure to adequately maintain the unit and provide a suitable cleaning schedule will result in performance degradation and reduce the life expectancy of the air-curtain).

Remove the back and inlet grille panels from the air curtain. Vacuum and clean the build-up of dirt and debris within the air-curtain (*please note that the motor(s) are permanently lubricated and require no additional lubrication*).

If the outer casing requires cleaning this should be done using a warm soft cloth. Do not use solvents or abrasive materials.

■ Warranty

If any problems are encountered, please contact your installer/supplier. Failing this please contact the Thermoscreens warranty department. All units are covered by a two year warranty period.

Care has been taken in compiling these instructions to ensure they are correct, although Thermoscreens disclaims all liability for damage resulting from any inaccuracies and/or deficiencies in this documentation. Thermoscreens retain the right to change the specifications stated in these instructions.

Thermoscreens Ltd
St. Mary's Road Nuneaton
Warwickshire England
CV11 5AU

Email: sales@thermoscreens.com
Tel: + 44 (0) 24 7638 4646
Fax: + 44 (0) 24 7638 8578
www.thermoscreens.com