

# Punto EVO Range

## Key features

- **Extremely quiet**  
26.9 Lp dB(A) for models Ø100
- **IP 45**  
High protection against jets of water suitable for installation in wet areas, such as bathrooms (even Zone 1), kitchens, laundries and basements.
- **Low power consumption**  
9 W for models Ø100
- **High performance**  
95 m<sup>3</sup>/h for models Ø100
- **Reduced depth**  
40,5 mm for models Ø100
- **Compact size**  
173 mm for models Ø100
- **Unique design**
- **Long Life 30.000 h**

## Product Specifications

- Front panel, motor holder and integrated backdraught shutter made of ABS thermoplastic shockproof and anti-UV resin.
- Helico-centrifugal mixed-flow impellers made of PP resin.
- Impellers and motor holder specifically designed for high performance, low power consumption and low noise emissions.
- Integrated butterfly backdraught shutter designed to prevent unwanted air inflows when the appliance is switched off.

- Long-life ball-bearing motors guaranteed for 30,000 hours continuous trouble-free operation.
- Designed to provide a low environmental impact, using recyclable materials and following the new “Design for Disassembly” technique to achieve easy and environmentally friendly disposal of components.
- Insulation class: II.

## Installation

- Designed for direct air extraction outside or through short ducts. (<3m)
- Typical wall/panel, false wall, ceiling and false ceiling installations.
- Reduced mounting depth makes it ideal to fit even when the installation space is limited due to the proximity of elbow bends (90°).



Punto EVO Whitegold (11309)

## Technical Specifications

Models	V ~ 50 Hz	W max	A max	RPM max	Max Airflow		Max Pressure		Lp dB(A) 3m
					m <sup>3</sup> /h	l/s	mmH <sub>2</sub> O	Pa	
Punto EVO Flexo	230	9	0.052	2175	90	25	4	39.23	26.9
Punto EVO/Gold	230	9	0.052	2240	90	26.4	4.7	46.09	26.9

## Pressure/Performance Curves

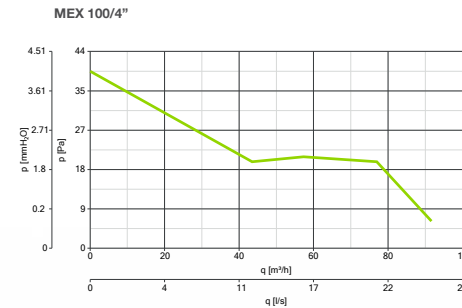

## Exploded View

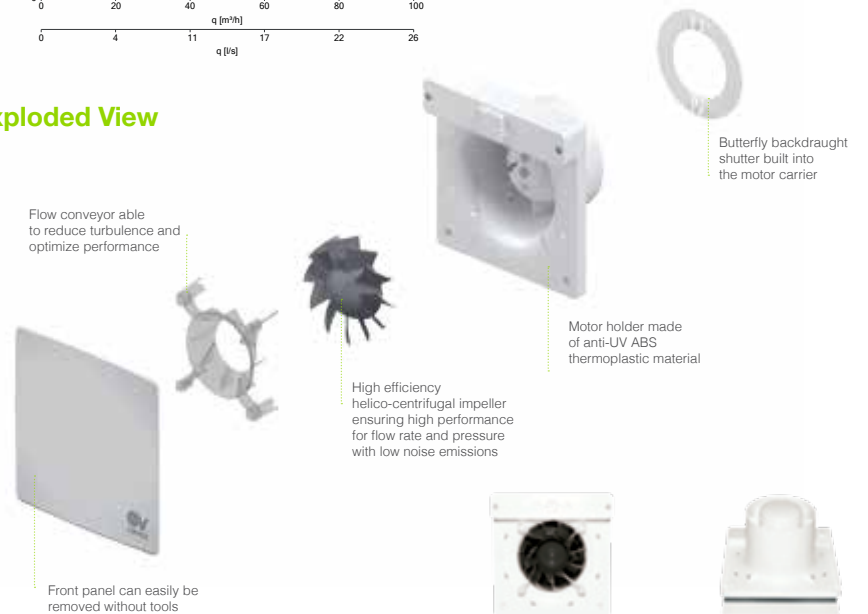

**Dimensions (mm)**

MODEL	A	B	C	D	E	F	G	H	L	KG
<b>EVO</b>	173	173	126	98	61.5	50	132	132	3.5	0.60
<b>EVO Gold</b>	173	173	126	98	61.5	50	132	132	3.5	0.60
<b>Evo Flexo</b>	173	73	126	98	61.5	50	132	132	3.5	0.60
<b>EVO Flexo 5</b>	193	93	138	119	71	53	152	152	3.5	0.77

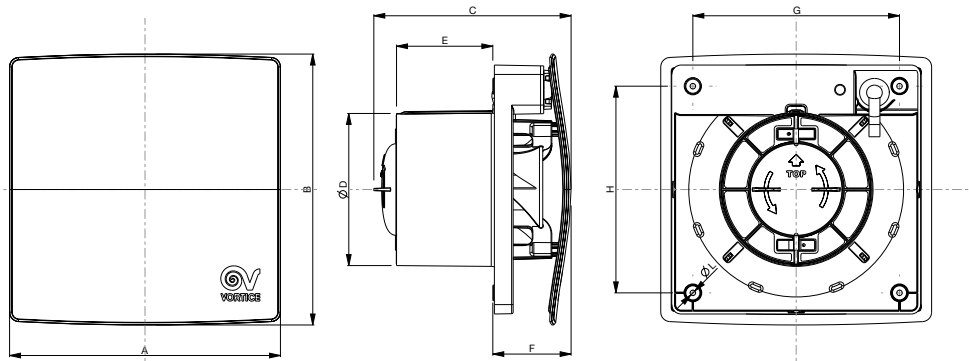

**Punto Evo**

Suitable for wall and ceiling installation; designed for stile air extraction through walls or short ducts with two-speed. 5 version: Standard, Timer (T), Advanced Timer (TP), Humidity Control (HCS), Infrared Motion Sensor (PIR).

**Punto Evo Gold**

The GOLD versions of PUNTO EVO feature a stylish metallic mirror finish in four colour nuances (Pink, Yellow, Black and White Gold) obtained through advanced technologies, providing an attractive and distinctive style, durability and wear resistance.

**EVO Flexo**

The Flexo version of the Punto EVO feature a plain white grill.



**EVO**

Model	Code
<b>ME 100/4" LL</b>	11260
<b>ME 100/4" LL T</b>	11264
<b>ME 100/4" LL TP</b>	11261
<b>ME 100/4" LL TP HCS</b>	11262
<b>ME 100/4" LL TP PIR</b>	11263

**EVO Flexo**

Model	Code
<b>ME 100/4" LL ES</b>	11268

**EVO Gold**

Model	Code
<b>ME 100/4" LL YELLOW GOLD</b>	11306
<b>ME 100/4" LL PINK GOLD</b>	11307
<b>ME 100/4" LL WHITE GOLD</b>	11309
<b>ME 100/4" LL T YELLOW GOLD</b>	11316
<b>ME 100/4" LL T PINK GOLD</b>	11317
<b>ME 100/4" LL T BLACK GOLD</b>	11318
<b>ME 100/4" LL T WHITE GOLD</b>	11319